

sessanta \

executive collection

PROFESSIONAL OFFICE
**PR
OF**

PROFESSIONAL OFFICE
PROF



company

Dall'esperienza nel settore del mobile, nel 1995 nasce Prof, una realtà industriale familiare che produce sistemi d'arredo per ufficio, fortemente radicata nel distretto del mobile del nord est italiano. In questi vent'anni il percorso di sviluppo e crescita economica di Prof l'ha condotta ad affacciarsi al mercato internazionale contribuendo a diffondere la qualità del design italiano nel mondo.

Avvalendosi della consulenza di architetti e designer l'azienda ha consolidato la propria identità e ampliato l'offerta di prodotti. Partendo dalle collezioni operative, ha sviluppato in seguito sistemi direzionali, soluzioni per la reception e le sale riunioni, fino alle pareti divisorie e attrezzate. Questo oggi le permette di proporre soluzioni di arredo complete e personalizzate per tutti gli ambienti di lavoro.

Prof was born in 1995 from the furniture sector experience, a family industrial reality that produces office furniture systems, deep-rooted in the Italian north-east furniture district. In these twenty years, Prof economic route of development and growth allowed it to look out to the international market contributing to the Italian quality design diffusion in the world.

Taking advantage from architects and designer consultancy, Prof strengthened its identity and it widened the products offer. Beginning from the secretarial collections, it then developed executive systems, reception and conference rooms solutions, getting up to separating and equipped wall. Today, this allows it to propose complete and customized furnishing solution for any working site.

design

In Prof ogni elemento d'arredo nasce dalla capacità di interpretare il continuo mutamento delle dinamiche negli ambienti di lavoro. La ricerca rappresenta da sempre l'elemento strategico nella politica di crescita aziendale e si esprime attraverso un Design Department interno, che opera a stretto contatto con i progettisti esterni ed è in costante aggiornamento con l'evoluzione tecnologica e normativa. Per questo motivo le collezioni Prof si distinguono per l'elevato design, l'ergonomia e la funzionalità.

In Prof company, any furnishing element rises from the ability to understand the constantly changing of the working places dynamics. The research has always represented the strategic element of the company policy of business growth and it expresses through an internal Design Department working closely in contact with external designers and it is constantly updating with the technological and legislative evolution. For this reason, Prof collections stand out for the high design, the ergonomics and the functionality.



quality and enviroment



Per rispondere alla crescente competitività nei mercati internazionali attraverso il miglioramento della soddisfazione e della fidelizzazione dei clienti, la razionalizzazione dei processi produttivi interni, Prof ha ottenuto nel 2012 la certificazione ISO 9001:2008. L'adozione di un sistema di gestione per la qualità rappresenta per Prof una decisione strategica che consente di raggiungere obiettivi aziendali sempre più concreti.

In un mondo costantemente alla ricerca della qualità e sempre più sensibile alle problematiche ecologiche, Prof mette in campo la massima professionalità nel progettare e produrre mobili per ufficio rispettando l'ambiente. Dalla materia prima accuratamente selezionata, all'intero processo di trasformazione e imballaggio fino allo smaltimento, tutto è finalizzato alla salvaguardia della salute ed al risparmio energetico. L'ottenimento nel 2012 della certificazione ISO 14001 ne dimostra l'impegno concreto. Oggi, in concomitanza con i venti anni dell'azienda, Prof lancia il suo nuovo marchio green per riconfermare e rendere riconoscibile il suo impegno verso il tema della sostenibilità ambientale, come parte integrante della propria attività e del proprio processo di crescita produttiva.

In order to answer to the increasing competitiveness of the international markets through the improvement of the customer satisfaction and loyalty, the rationalizing of the internal producing processes, Prof attained ISO 9001:2008 certification in 2012. The adoption of a quality management system represents for Prof a strategic decision giving the possibility to achieve business objectives more and more concrete.

In a world steadily looking for the quality and increasingly sensible to ecological problems, Prof puts in place the maximum expertise in the office furniture design and production while respecting the environment. Starting from the carefully selected raw material, the whole process of transformation and packaging up to the disposal, all aims at the health safeguarding and at energy saving. In 2014, the obtainment of ISO 14001 certification demonstrates the concrete commitment.

Today, at the same time of the company twenty years, Prof launches its new green mark to confirm and make identifiable its commitment towards the environmental sustainability as integral part of its activity and of its process of production growth.





index \ pages

sessanta	executive collection	09
	dark mood	10
	warm mood	48
	technical characteristics	79
	finishings	81
	technical data	82
	canalization	92
	accessories	94



sessanta \ executive collection

Sessanta è una collezione direzionale di scrivanie, contenitori e tavoli riunione.

Combina un'accurata selezione di materiali da giocare in armonia e alternanza nelle superfici e nei volumi degli arredi. Lo spessore 60 mm è il filo conduttore che contraddistingue e lega gli elementi della collezione. Due le tonalità di olmo: la versione miele, chiara e calda e la versione lava, bruna e avvolgente. In abbinamento, le tinte unite dai toni opachi come il beige, il tabacco, il basalto e il rame. A completare, la pelle in tre nuance di colore che vanno dal cuoio, al testa di moro e al basalto, per arricchire le superfici dello spazio di lavoro.

La scrivania è declinata in numerose versioni, ciascuna corredata da complementi che la rendono estremamente adattabile ai vari spazi di lavoro direzionali. Dalle linee semplici ed essenziali, è caratterizzata da una forma a portale in forte spessore, in appoggio da un lato su un elemento funzionale in sporgenza, che in due diverse profondità, alloggia una cassettera e dei vani accessori.

I contenitori in tre altezze sono variamente attrezzati con cassettoni, vani a giorno, ante a battente e a ribalta.

I tavoli riunione rotondi e rettangolari hanno piani componibili che accostati disegnano un incrocio di venature.

Completano la collezione, una serie di tavolini caffè in diverse altezze e profondità e una consolle in due varianti dimensionali, con vani a giorno e cassetti.

Sessanta is an executive desks collection, cabinets and conference tables. It combines a careful materials selection to play in harmony and alternatively on the surfaces and on the furniture volumes. The thickness of 60 mm is the common thread that characterizes and binds the collection elements.

Two elm shades: honey version, light and warm and the lava version, brown and enveloping. In conjunction, the solid colors with matt tone like beige, tobacco, basalto and copper.

To complete, the leather in three color nuances going from leather, dark brown and basalto, to enrich the working space surfaces.

The desk has many versions, anyone equipped with complements making it extremely adaptable to different executive working spaces. Having simple and essential lines, it is characterized by a high thickness double shape, leaning on a function overhung element on one side, that accommodates a pedestal drawer and some accessory compartments in two different depth.

The cabinets in three different heights are differently equipped with dressers, open spaces, hinged and folding doors.

The round and rectangular conference tables have modular tops drawing a cross veins pattern when approached.

The collection is completed by a range of coffee tables with different height and depth and a console in two different measures with open compartments and drawers.

design RMDESIGNSTUDIO

dark mood

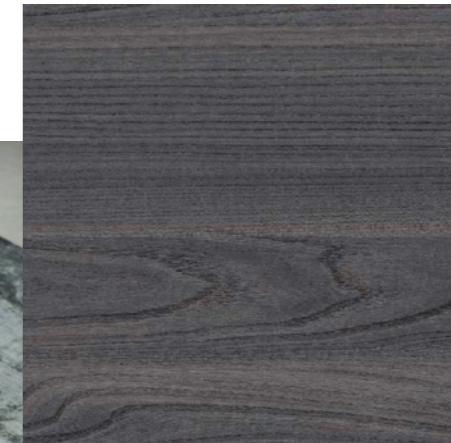

Suggerimenti materiche del legno e della pelle nei toni caldi e scuri. Proposte di arredo in grado di declinarsi in differenti interpretazioni stilistiche, sempre in armonia con l'architettura degli spazi.

Wood and leather material suggestions in warm and dark tones. Furnishing proposals growing in different stylistic interpretations, always in harmony with the spaces architecture.





**01 olmo lava, pelle testa di moro e beige
lava elm, dark brown leather and beige**

In apertura e nelle pagine precedenti: pelle e legno, materiali primari tradizionali per una nuova definizione dello spazio ufficio contemporaneo.

La scrivania è in grado di integrare perfettamente vari elementi funzionali. Qui è presentata nella versione *executive desk* con cassetiera portante. Dietro trovano spazio i contenitori bassi dalle forme essenziali e privi di maniglie. Un'alternanza di pieni e vuoti in diverse finiture ne scandisce il ritmo.
Sopra: consolle in versione asimmetrica con frontali rivestiti in pelle.

In the opening and in the previous pages: leather and wood, traditional primary materials for a new definition of the modern office space.

The desk can perfectly integrate various functional elements. Here it is introduced with supporting drawers in the *executive desk* version. Low cabinets behind with essential shapes and without handles. An alternation of full and empty in different finishing sets its rhythm.
Above: console in asymmetric version with leather covered frontals.



I tavoli riunione sono caratterizzati da piani divisi e accostati in un raffinato gioco di geometrie. Racchiudono al centro un vano leggermente ribassato che accoglie i cablaggi. In queste pagine una suggestiva proposta con piani in pelle testa di moro in accostamento con le venature del legno.

The meeting tables are characterized by separated tops and approached in a sophisticated play of geometries. These encase a slightly lower compartment in the center for the cabling system. In these pages, a suggestive proposal with dark brown leather top in combination with the wood veins.



Equilibrio di volumi ed essenzialità delle forme. La consolle è caratterizzata da cassetti sporgenti di forte spessore. Qui è proposta nella configurazione simmetrica con frontali in pelle testa di moro, impreziositi da cuciture tono su tono.

Volumes balance and forms simplicity. The console is characterized by jutting drawers of a high thickness. Here a symmetrical configuration is proposed in dark brown leather, enriched by tone on tone stitching.





**02 olmo lava, pelle basalto e beige
lava elm, basalt leather and beige**

In apertura e nella pagina precedente: forme semplici ed essenziali arricchite dalle venature del legno e dalla qualità esclusiva della pelle con cuciture a vista. Proposta di scrivania nella configurazione executive desk con piano dattilo e cassetiera portante.

In the opening and in the previous page: simple and essential forms enriched by the wood veining and the exclusive quality of the leather with visible stitching. Desk proposal in the layout executive desk with extension top and supporting drawers unit.





In questa e nella pagina precedente: tavolo riunione rettangolare caratterizzato da un'alternanza di piani in pelle e legno in raffinati abbinamenti materici.
In alto: dettaglio del funzionale vano porta cavi interamente rivestito in pelle.
Sotto: armadi contenitori composti da ante a battente, cassettoni in pelle ad estrazione totale e vani a giorno.
In this and in the previous page: rectangular conference table characterized by a top alternation in leather and wood with refined combinations of materials.
Upward: detail of the functional compartment trays completely covered in leather.
Underneath: cabinets composed by swing doors, leather total extraction filing drawer and open spaces.





In queste pagine: madia alta nella combinazione olmo lava, pelle basalto e tonalità beige. Superfici essenziali scandite dal ritmo visivo delle diverse configurazioni delle ante.

Nel dettaglio: particolare del cassetto con frontale sporgente in forte spessore e anta ribalta orizzontale, entrambi in pelle.

In these pages: high sideboard in elm lava, basalto and beige tones combination. Essential surfaces marked by the visual rhythm of the different doors configuration.

In the detail: dresser detail with jutting frontal of high thickness and folding door, both in leather.



Tavolo rotondo per piccole riunioni con base metallica.
Suggerimenti materiche della pelle, con una lavorazione caratterizzata dalle cuciture a vista.

Round table for small meeting with metal base. Leather material suggestions with a manufacture characterized by the visible stitching.





**03 olmo lava, basalto e tabacco
lava elm, basalt and tobacco**

Pagine precedenti e questa: Massima funzionalità e prestigio per la scrivania in versione president desk, che integra un ampio mobile di servizio con cassetiera e vani contenitori.

Previous pages and this one: maximum functionality and prestige for the president desk version integrating a wide service cabinet with drawers and storage compartments.



Nella pagina accanto: tavolo riunione con particolare incrocio tra le venature dei piani.

Sopra: variante della scrivania president desk con funzionale mensola in appoggio che amplia la superficie di lavoro.

Nella pagina successiva: essenzialità assoluta per la scrivania in versione president wood desk, contraddistinta da un'unica finitura in legno.

In the previous page: conference table with particular intersection between the tops veins.

Upward: variation of the president desk with functional shelf widening the working space.

In the following page: absolute essentiality for the desk in the version president wood desk, distinguished by an only wood finishing.





Grande versatilità compositiva caratterizza gli elementi della collezione Sessanta: nell'immagine i tavolini caffè, con soluzioni che si affiancano al divano e a centro stanza.

Sopra: i contenitori della collezione sessanta sono in grado di declinarsi in differenti interpretazioni stilistiche, attraverso il libero accostamento di due o tre finiture.

Suggestivo abbinamento di tre finiture per la madia proposta in olmo lava, tabacco e basalto.

Great versatility of composition distinguishes the elements of Sessanta collection: in the image, the coffee tables with solutions that put beside to the sofa and on the room center. Upward: Sessanta collection cabinets that can get different stylistic interpretations thanks to the free approach of two or three finishing.

Charming combination of three finishing for the sideboard propose in lava elm, tobacco and basalt.





**05 olmo lava, tabacco e rame
lava elm, tobacco and copper**

Nelle pagine precedenti: semplificazione delle linee e perfetta integrazione degli elementi funzionali. Scrivania manager desk con piano dattilo nell'abbinamento olmo lava e tabacco.

Sopra: tavolo riunioni rotondo con piani in legno composti con venature incrociate.

In the previous pages: simplification of the lines and perfect functional elements integration. Manager desk with extension top in the lava elm and tobacco combination.

Upward: round conference table with composed wood tops having cross-veins feature.



Tavolini caffè e consolle interpretano l'area relax dedicata alla conversazione. In alto: dettaglio dei tavolini caffè rettangolari e quadrati, disponibili anche con funzione portariviste. Nella pagina successiva: vista d'insieme delle consolle, elementi funzionali dalle linee semplici e rigorose. Grazie alla loro versatilità, sono di grado di arredare con eleganza ogni spazio dell'ambiente di lavoro.

Coffee tables and console portray the relax area dedicated to the conversation. Upward: detail of the rectangular and square coffee tables available also with magazine rack function. In the following page: overall view of the consoles, functional elements with simple and rigorous lines. Thanks to their versatility, they can furnish any working space with elegance.



warm mood



Le calde sfumature naturali del legno e della pelle dialogano con la neutralità dei colori. Proposte che caratterizzano fortemente gli spazi e creano atmosfere di naturale eleganza.

The warm natural nuance of the wood and the leather talk with the colors neutrality. Proposals that strongly characterize the spaces and create natural elegance atmospheres.





**06 olmo miele e beige
honey elm and beige**

Nelle pagine precedenti: calde venature e tonalità naturali per la scrivania executive desk con vano contenitore portante e piano dattilo. Sopra: in abbinamento materico la console qui proposta nella versione simmetrica.

In the previous pages: warm veins and natural tones for the executive desk with supporting storage compartment and extension top. Upward: the console in material combination here proposed in symmetric version.





In apertura e sopra: ampie proporzioni e geometrie essenziali per il tavolo riunione con finiture a contrasto.
 A sinistra: la dinamica fra pieni e vuoti e l'abbinamento tra le finiture sono gli elementi che definiscono l'estetica dei contenitori della collezione Sessanta. Madie basse proposte in olmo miele con vani a giorno beige.

In the opening and upward: wide proportions and essential geometries for the conference table with contrasting finishes.
 On the left: the dynamic between full and empty spaces and the combination between the finishing are the elements defining the cabinets aesthetics of Sessanta collection. Low sideboards proposed in honey elm with beige open spaces.





**07 olmo miele, basalto e rame
honey elm, basalt and copper**

Nelle pagine precedenti: scrivania in versione manager desk con cassetiera mobile. Una soluzione compositiva di grande essenzialità scandita dall'alternarsi delle finiture.

In alto: nei contenitori gli elementi a giorno orizzontali e verticali rappresentano un dettaglio di personalità in un'estetica rigorosa.

Nelle pagine seguenti: area meeting con tavolo riunione e coppia di madie a completamento.

In the previous pages: manager desk version with moving pedestal drawer. One compositional solution of great simplicity marked by the finishes alternation.

Upward: in the cabinets, the horizontal and vertical open spaces represent a detail of personality in a rigorous aesthetic.

In the following pages: meeting area with conference table and completion sideboards.







**08 olmo miele, beige, basalto
e pelle tinta cuoio
honey elm, beige, basalt
and cuoio leather**

Nelle pagine precedenti: una proposta dalla forte valenza espressiva per la scrivania nella configurazione president desk.

Accanto: particolare del modesty panel rivestito in pelle. In basso: geometrie primarie per i tavolini caffè disponibili in tre versioni dimensionali, che offrono la possibilità di formulare soluzioni d'arredo dalla massima libertà compositiva.

In the previous pages: a proposal of strong expressive value for the president desk configuration.

Next: modesty panel detail leather covered. Underneath: primary geometries for the coffee tables available in three dimensional versions that give the possibility to formulate furnishing solutions with the maximum compositional freedom.





A sinistra e sotto: ampio tavolo riunione, dalle forme essenziali per valorizzare al massimo la varietà delle finiture e le loro possibilità compositive. Vista dall'alto sul vano passacavi, enfatizzato dalla finitura a contrasto in pelle. Accanto: madia con cassettoni dal frontale in pelle.

On the left and underneath: wide conference table with essential forms to maximize the finishes variety and its compositional possibility. Top view of the cable compartments, emphasized from the finishing in contrast with the leather. Beside: sideboard with front dresser in leather.





In alto: soluzione monomaterica per la scrivania in versione president wood desk e per le madie alte.

A sinistra: variante con mensola complanare.

Upward: single material solution for the president wood desk and for the high sideboards.

On the left: variation for the complanar shelf.







**09 olmo miele, tabacco e basalto
honey elm, tobacco and basalt**

Nelle pagine precedenti: un ufficio di prestigio, per un'immagine di eleganza contemporanea. Scrivania *executive desk* con cassetteria portante accostata al tavolo meeting rotondo con piani in legno e alle madie giocate in una combinazione di tre finiture.

In the previous pages: a prestigious office, for an image of modern elegance. *Executive desk* with supporting drawers drawn near the round meeting table with wood tops and sideboards in a combination of three finishes.



sessanta \ technical characteristics

finishings	81
technical data	82
canalization	92
accessories	94

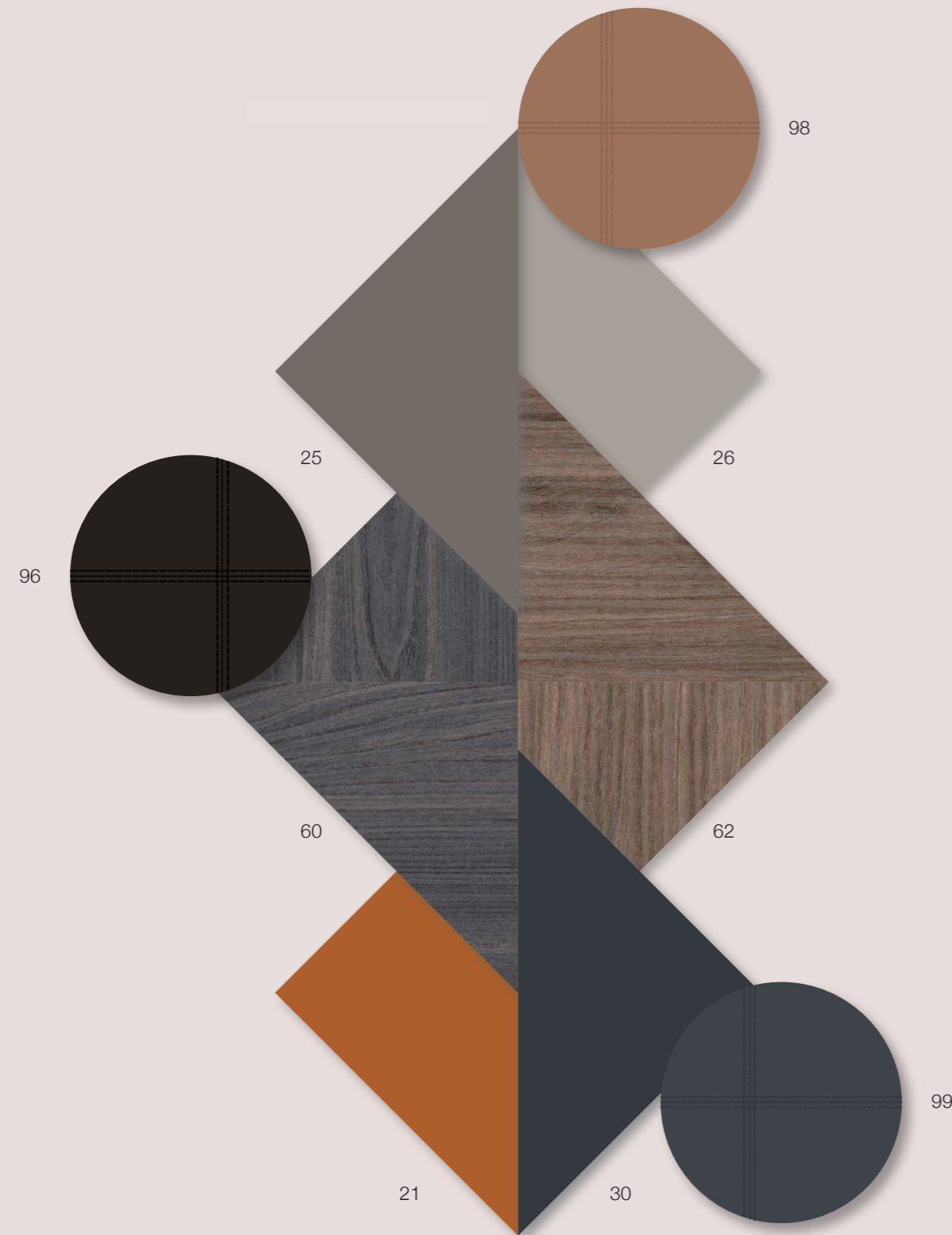

finishings \ chromatic proposals

Le forme pure e le linee essenziali della collezione sono enfatizzate dalla combinazione dei materiali, che creano un raffinato contrasto tra la matericità del legno e della pelle e i toni neutri e opachi delle tinte unite.

Olmo lava e olmo miele

Due le diverse tonalità che esaltano la bellezza delle venature del legno. Calde sfumature naturali per la versione miele. Toni scuri ed eleganti per la versione lava.

Colore

In accostamento cromatico al ritmo delle venature del legno ci sono quattro tonalità opache: beige, tabacco, basalto e rame. Una palette essenziale di chiaroscuri, vivacizzata da unico accento di colore giocato in piccoli dettagli.

Pelle

In abbinamento materico sono disponibili tre nuance di colore della pelle: cuoio, testa di moro e basalto con cui si possono rivestire il modesty panel della scrivania, i piani dei tavoli riunione, i frontali dei cassetti e le ante dei contenitori.

The pure shapes and the essential lines of the collection are emphasized by the materials combination creating a refined contrast between the materiality of the wood and of the leather and the neutral and matt tones of the solid colours.

Lava elm and honey elm

Two different tonalities exalt the beauty of the wood grain. Warm natural shades for the honey option. Dark and elegant shades for the lava option.

Solid colours

There are four dull tonalities in color combination to the rhythm of the wood grain: beige, tobacco, basalt, copper. An essential palette of light and dark, enlivened from an only color accent played in small details.

Leather

Three leather colour nuances are available in material combination: leather, dark brown and basalt which you can cover the desk modesty panel with, the meeting tables top, the pedestal frontal drawers and the cabinets doors.

Legno	Colore	Pelle
60 olmo lava	26 beige	98 cuoio
62 olmo miele	25 tabacco	96 testa di moro
	21 rame	99 basalto
	30 basalto	

Wood	Colour	Leather
60 lava elm	26 beige	98 cuoio
62 honey elm	25 tobacco	96 dark brown
	21 copper	99 basalt
	30 basalt	

sessanta manager desk



Scrivania con gambe e piano pannellati. Può essere accessoriata con work extension sempre posizionato sul lato opposto all'apertura nel modesty panel. Piani e gambe sono disponibili nelle finiture olmo lava e olmo miele, il modesty panel in tutte le finiture legno, colori e pelli a catalogo.

Desk with paneled top and legs. It can be equipped with work extension always assembled on the opposite side of the modesty panel opening.

Tops and legs are available in lava elm and honey elm finishes, the modesty panel in all of wood finishes, colors and leathers in the catalogue.

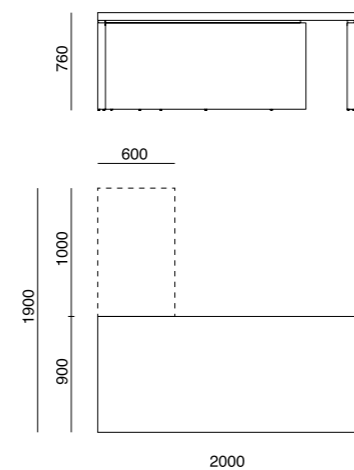

sessanta executive desk



Soluzione con cassetteria o vani a giorno portanti e integrati al modesty panel che possono essere posizionati a destra o a sinistra rispetto alla posizione del fruitore. La scrivania può essere corredata da un ampio work extension sempre posizionato sul lato opposto all'apertura nel modesty panel. Piani, gambe e pannelli decorativi sono disponibili nelle finiture olmo lava e olmo miele, il modesty panel in tutte le finiture legno, colori e pelli a catalogo.

Solution with supporting pedestal drawers and open compartments integrated in the modesty panel that can be assembled on the user right or left position. The desk can be supplied with a wide work extension always located on the opposite side of the modesty panel opening. Tops, legs and decorative panels are available in lava elm and honey elm finishes, the modesty panel in all of wood finishes, colors and leathers in the catalogue.

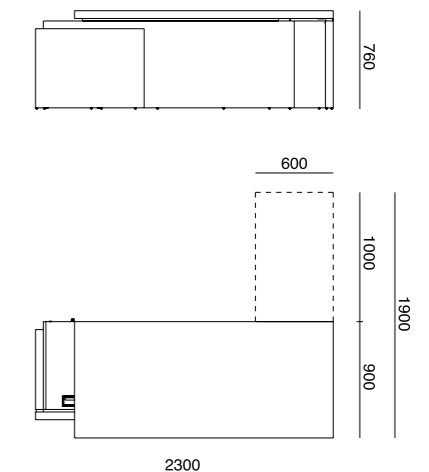

Variante con vani a giorno
Variant with open compartments

sessanta president desk



Scrivania con mobile servente integrato che può essere posizionato a destra o a sinistra rispetto alla posizione del fruitore. È dotato di vani a giorno, cassetiera e a richiesta di una mensola in appoggio complanare al piano. Piani, gambe e pannelli decorativi sono disponibili nelle finiture olmo lava e olmo miele, il modesty panel in tutte le finiture legno, colori e pelli a catalogo.

Desk with integrated service unit that can be assembled on the user right or left position. It has got open compartments, pedestal drawer and a leaning shelf the same height of the top.

Tops, legs and decorative panels are available in lava elm and honey elm finishes, the modesty panel in all of wood finishes, colors and leathers in the catalogue.



Variante con mensola complanare
Variant with complanar shelf

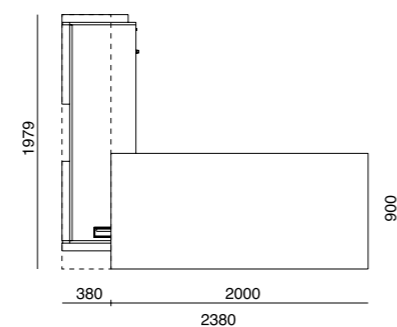
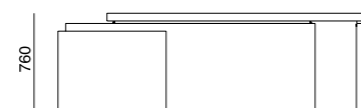

sessanta president wood desk



Scrivania con mobile servente integrato che può essere posizionato a destra o a sinistra rispetto alla posizione del fruitore. È dotato di vani a giorno, cassetiera e mensola in appoggio che amplia lo spazio di lavoro. Questa configurazione è disponibile nelle finiture olmo lava e olmo miele.

Desk with integrated service unit that can be assembled on the user right or left position. It has got open compartments, pedestal drawer and a leaning shelf enlarging the working space.

This configuration is available also in lava elm and honey elm finishes.

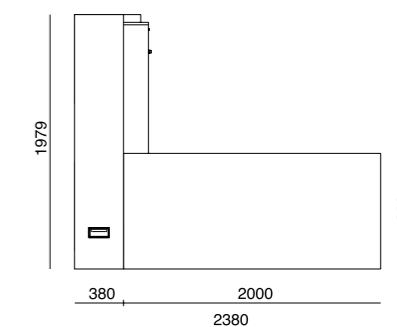

sessanta meeting tables

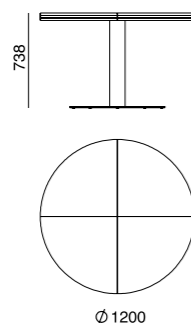

Tavolo circolare con basamento metallico verniciato color basalto opaco. Il piano in legno sp. 60 mm con caratteristico incrocio delle venature, è disponibile nelle finiture olmo opaco e olmo miele.

Round table with metal basement varnished in matt basalt color. The wood top 60 mm thick with distinctive cross veins is available in lava elm and honey elm finishes.

Serie di tre tavoli rettangolari con piani e basamento in legno. Il top sp. 60 mm è composto da piani accostati con caratteristico incrocio delle venature. I piani sono disponibili nelle finiture olmo lava e olmo miele o in pelle nelle tre varianti a catalogo e possono essere liberamente combinati tra loro. La fascia centrale ribassata porta i cablaggi sul piano di lavoro. Può essere in tutte le finiture, colori e pelli a catalogo. Il basamento si può avere in un unico materiale nelle finiture olmo lava e olmo miele e con modesty panel colorato nelle quattro tinte a catalogo.

Three rectangular tables with tops and basement in wood. The top 60 mm thick is composed by drawn near tops with distinctive cross veins. The tops are available in lava elm and honey elm finishes or in three leather versions as in the catalogue and they can be freely combined together. The central lowered band in lava elm and honey elm finishes carries the wiring on the working top. It can be in all finishes, colors and leathers as in the catalogue. The basement can be delivered in an only material in lava elm and honey elm finishes and with the modesty panel as per four catalogue colors.

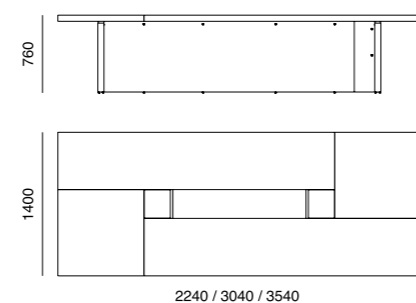

sessanta aggregated meeting tables

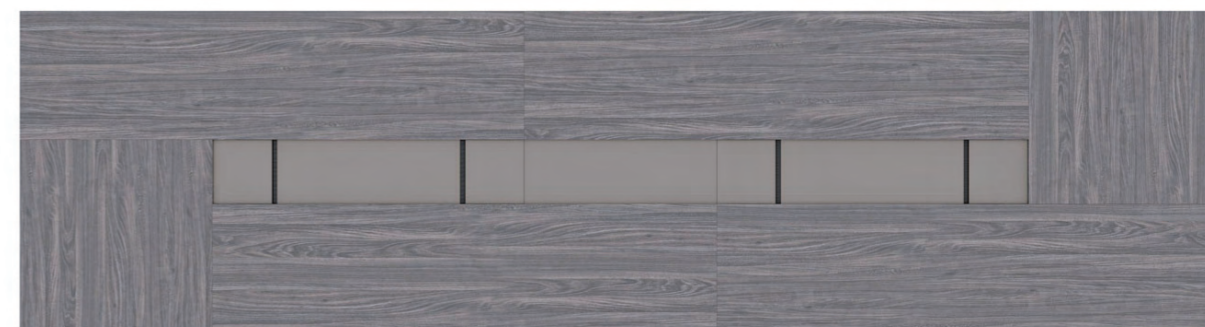

Tavoli rettangolari di grandi dimensioni con piani componibili e basamento in legno dalla gamba centrale condivisa. I tops sp. 60 mm sono disponibili nelle finiture olmo lava e olmo miele o in pelle nelle tre varianti a catalogo e possono essere liberamente combinati tra loro. La fascia centrale ribassata porta i cablaggi sul piano di lavoro. Può essere in tutte le finiture legno, colori e pelli a catalogo. Il basamento si può avere in un unico materiale nelle finiture olmo lava e olmo miele e con modesty panel colorato nelle quattro tinte a catalogo.

Wide dimensions rectangular tables with modular tops and wood basement with central sharing leg. The tops 60 mm thick are available in lava elm and honey elm finishes or in three leather versions as in the catalogue and they can be freely combined together. The central lowered band in lava elm and honey elm finishes carries the wiring on the working top. It can be in all finishes, colors and leathers as in the catalogue. The basement can be delivered in an only material in lava elm and honey elm finishes and with the modesty panel as per four catalogue colors.

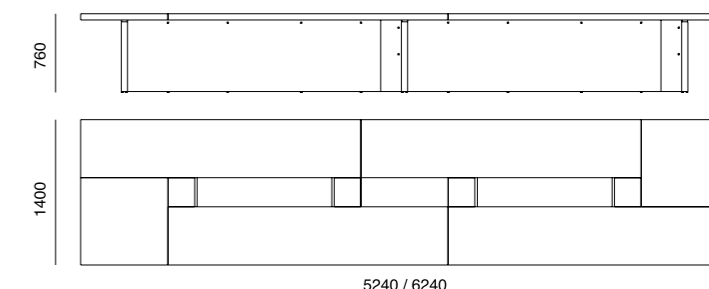

sessanta cabinets

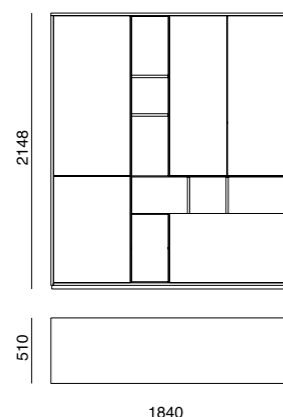
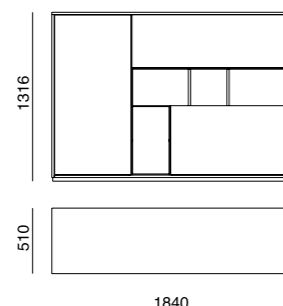
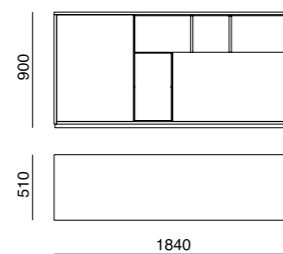

Collezione di contenitori in tre altezze con scocca nelle finiture legno.
Le ante a battente ad apertura push to open, sono disponibili nelle finiture legno e colore.
Gli elementi a giorno orizzontali e verticali nei quattro colori a catalogo.
Il cassettone ad estrazione totale con anta sp.60 mm nelle finiture legno e pelle.
Il mobile contenitore H.1316 mm è dotato di anta a ribalta ad apertura push to open in tutte le finiture a catalogo.

Collection of cabinets in three different height and wood finish structure. The hinged doors with push to open opening are available in wood and color finishes. The horizontal and vertical open compartments are available in four colors as per the catalogue. The total extraction dresser with 60 mm thick door in wood and leather finishes.
The cabinet H.1316 mm has got a flap door with push to open opening in all of the catalogue finishes.

sessanta consolle



Consolle in due varianti di lunghezza con struttura in olmo lava e olmo miele.
Frontali sp. 60 mm disponibili nelle finiture legno e pelle con guide a estrazione totale.
Ripiano e fianco centrale nei quattro colori a catalogo.

Console in two different lengths with lava elm and honey elm structure.
Front drawers 60 mm thick available in wood and leather finishes with total extraction guides. Shelf and central side in four colors as per the catalogue.

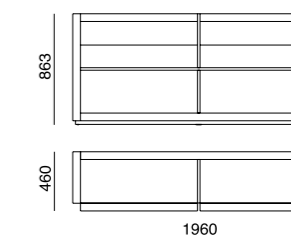
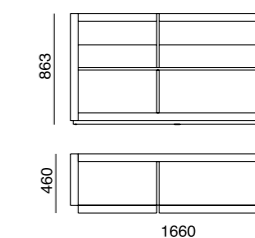

sessanta coffee tables

Collezione di tavolini quadrati e rettangolari e portariviste con struttura nelle finiture olmo lava e olmo miele e piani nelle quattro tinte unite a catalogo.

Square and rectangular coffee tables and magazine rack collection with lava elm and honey elm structure and the tops in four colors as per the catalogue.

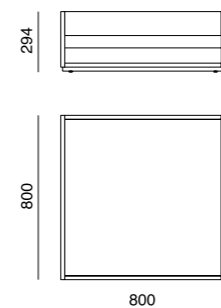
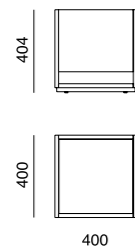
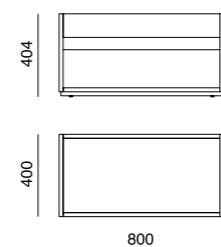
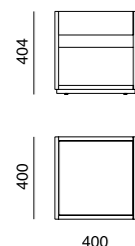

sessanta drawers unit

Cassettiera su ruote con tre cassetti ad estrazione totale e serratura. Disponibile nelle finiture olmo lava e olmo miele.

Pedestal drawers unit with three total extraction drawers and lock. Available in lava elm and honey elm finishes.

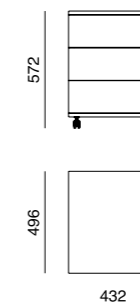

sessanta desk's wiring



La scrivania può essere dotata di top access in alluminio per consentire il collegamento delle apparecchiature elettriche.

The desk can be equipped with an aluminium access top to allow the internal devices connection.

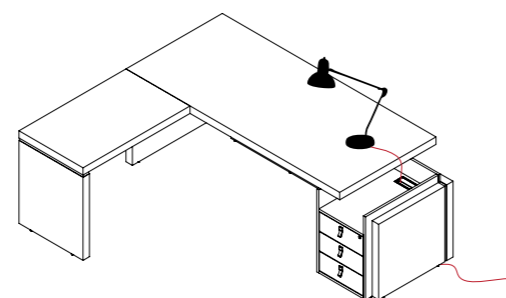

executive desk

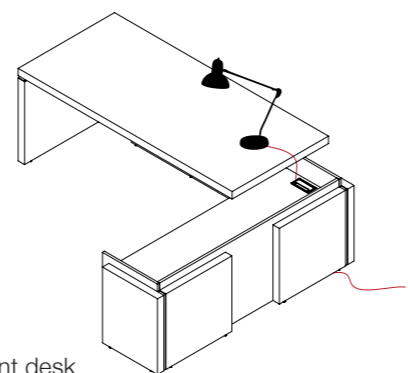

president desk

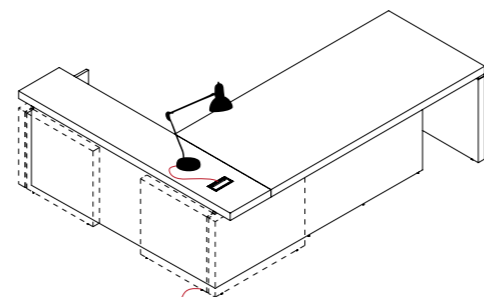

president desk
president wood desk

sessanta meeting table's wiring

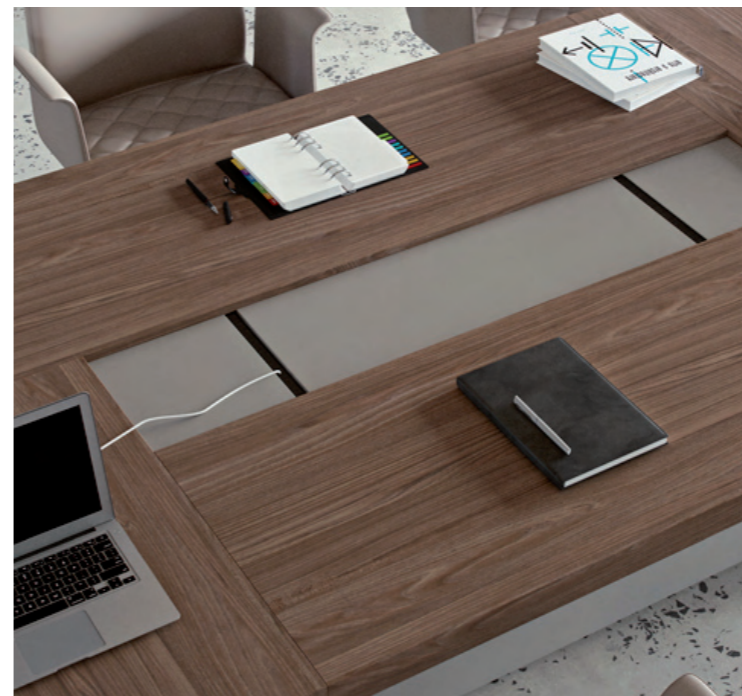

I tavoli riunione rettangolari sono dotati di top access con due sportelli per la canalizzazione posti alle estremità della fascia centrale.

The rectangular conference tables have a top access with two cabling small doors at the end of the central band.

finiture top access
top access finishings

finitura melaminico / melamine finishing

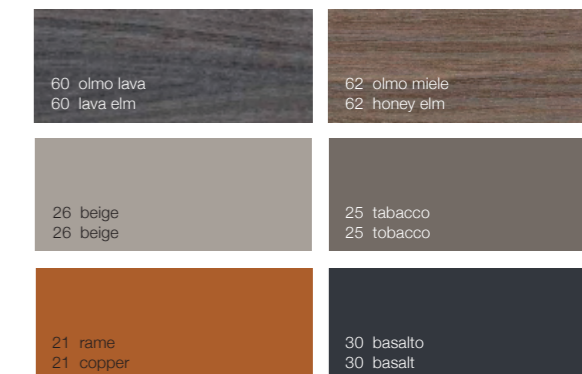

finitura pelle / leather finishing

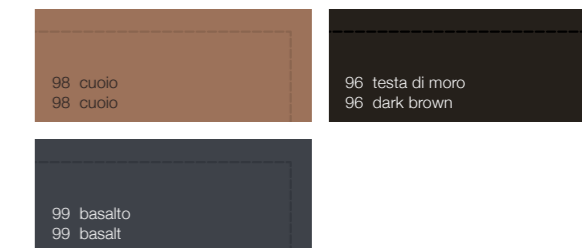

colori e materiali hanno valore indicativo
colour and materials have an indicative value

accessories

sessanta equipments and handles



Tutti i contenitori della collezione Sessanta hanno il cassettone ad estrazione totale con anta sp.60 mm e struttura in alluminio. Il frontale è disponibile nelle finiture olmo lava, olmo miele e pelle nelle tinte cuoio, testa di moro e basalto.

All of Sessanta collection cabinets have got the total extraction filing drawer with 60 mm thick door and aluminium structure. The front drawer is available in lava elm, honey elm and leather finishes in leather, dark brown and basalt colors.



Il mobile contenitore H.1316 mm è dotato di anta a ribalta ad apertura push to open ed è disponibile in tutte le finiture a catalogo.

The cabinet H.1316 mm has got a flap door with push to open opening in all of the catalogue finishes.



I contenitori sono attrezzati con ripiani in vetro trasparente. Le ante a battente hanno apertura push to open e si possono avere nelle finiture olmo lava, olmo miele e nei colori beige, tabacco, rame e basalto. Gli elementi a giorno orizzontali e verticali nei colori beige, tabacco, rame e basalto.

The cabinets are furnished with transparent glass shelves. The hinged doors have got the push to open opening and they can be supplied in lava elm, honey elm finishes and in beige, tobacco, copper and basalt colors. The horizontal and vertical open compartments are in beige, tobacco, copper and basalt colors.



La cassettera portante è corredata di serratura e pomelli a ciondolo in alluminio e pelle testa di moro.

The supporting pedestal is furnished with pendant lock knobs aluminium and dark brown leather finishes.

L'azienda si riserva in qualunque momento di apportare senza preavviso modifiche a prodotti e accessori.

The Manufacturer reserves the right to modify products and accessories at any time without prior notice.

UNI PROF products are according to UNI standard



CEE standard



low emission of formaldehyde



productions process that respect the ambient



AD & graphic project
RMDESIGNSTUDIO

design
RMDESIGNSTUDIO
R&S PROF

visualization
DELTA TRACING

PROFESSIONAL OFFICE
PROF

PROF srl
Via Cao de Villa 6/A
31020 Falzè di Piave, TV / Italy
T. +39 0438 903190 F. +39 0438 903228
p.iva / cod.fisc IT03134570260
www.proffice.it info@proffice.it
